

## FULLY AUTOMATIC TRAY FORMER

### MODEL TF-300B



**IPak's Model TF-300B** fully automatic tray former is designed and built to withstand the rigors of continuous, heavy-duty, industrial applications. The TF-300B automatically forms B.T.B. style trays suitable for agricultural, food processing, distribution and many other applications. It will continuously operate at speeds of up to 20 trays per minute and is capable of forming a wide range of tray sizes. Size changes are quick and easy, and can be performed in less than 20 minutes. Like all IPak machinery, the TF-300B is known for reliability and dependability and is backed by IPak's friendly and knowledgeable service team.

IPak Machinery - it simply works better

**IPak Machinery Ltd.**  
Supplying Effective Packaging Solutions

## STANDARD FEATURES

- All mechanical drive train
- Easy load hopper
- Venturi type vacuum pick system
- Offset dual vacuum cam design
- Corrosion resistant construction
- Remote Demand Controlled
- Nordson hot melt adhesive system
- All controls 24 Volts DC
- Allen-Bradley PLC
- Fully interlocked safety guarding

## OPTIONAL FEATURES

- Large capacity glue system
- Quick size change features
- Left or right hand controls
- Custom voltages
- Modifications for under or oversize cases
- High speeds - over 20 trays per minute
- Choice of hot melt glue systems
- Low hopper sensor
- Motorized outfeed conveyor
- Choice of PLC

## MACHINE SPECIFICATIONS

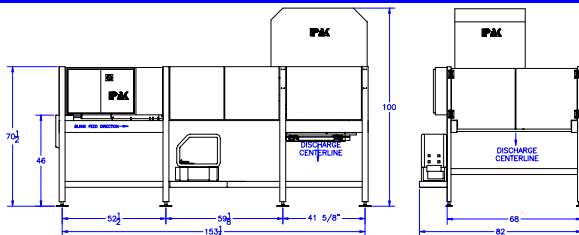

- Machine weight: 3500 lbs.
- Machine length (typical): 12'9"
- Air: 1.0 cubic feet per cycle at 90 p.s.i.
- Electrical: 230/460 Volts AC, 3 phase, 60 Hz
- Speeds up to 25 trays per minute
- PLC operated sequence and timing control
- External digital glue pattern timing controls
- NEMA 12 control panel
- Nordson hot melt adhesive system
- Lock-out / tag-out compliant

## FORMING SEQUENCE

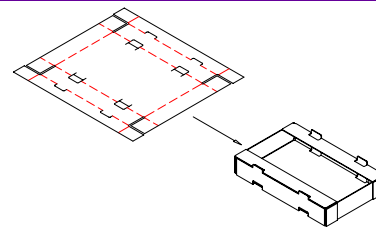

## METHOD OF OPERATION

The TF-300B hopper is loaded with die cut blanks. Vacuum cups pull the blanks onto the lug and chain drive. Adhesive is applied, then the blank is impacted and folded by a forming mandrel. The top flaps and flanges are then folded and compressed, and the finished tray is ejected upright onto a conveyor ready for filling.

## SOME EXAMPLES OF TRAYS FORMED ON THE TF-300B

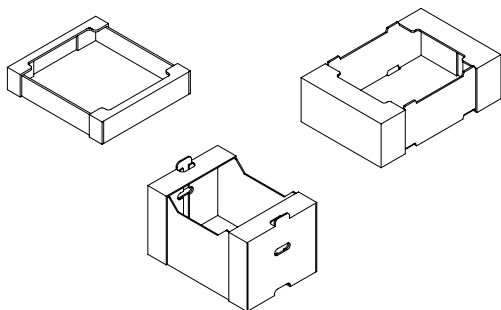

## THE IPAK PRODUCT LINE INCLUDES:

- |                 |                          |
|-----------------|--------------------------|
| Tray Formers    | Flange Sealers           |
| Case Sealers    | Stackers and De-Stackers |
| Sleeve Wrappers | Custom Applications      |

## DISTRIBUTED BY:

## IPak Machinery Ltd.

160-6165 Highway #17, Delta, BC, Canada V4K 5B8 Phone (604) 940-8073 Fax (604) 940-8074  
 Email: sales@ipakmachinery.com www.ipakmachinery.com