

FULLY AUTOMATIC TRAY FORMER

MODEL TF-200D



IPak's Model TF-200D fully automatic dual tray former is designed and built to withstand the rigors of continuous, heavy-duty, industrial applications. The TF-200D will form regular slotted trays in various configurations including four corner glued trays, one and two piece telescoping trays, and variations of self-locking trays suitable for most any application including agricultural, meat packing, food processing and distribution. The two sides of the machine produce trays simultaneously, however each side of the machine operates independently of the other, thereby allowing one side to operate while the other is being adjusted to run a different size or configuration of tray. The TF-200D will continuously operate at speeds of up to 35 trays per minute per side and is capable of forming a wide range of tray sizes. Size changes are quick and easy, performed in less than 10 minutes. Like all IPak machinery, the TF-200D is known for reliability and dependability and is backed by IPak's professional service team.

IPak Machinery - it simply works better

IPak Machinery Ltd.
Supplying Effective Packaging Solutions

STANDARD FEATURES

- All mechanical drive train
- Easy load hopper
- Venturi type vacuum pick system
- Offset dual vacuum cam design
- Corrosion resistant construction
- Remote Demand Controlled
- Nordson hot melt adhesive system
- All controls 24 Volts DC
- Omron PLC
- Fully interlocked safety guarding

OPTIONAL FEATURES

- Large capacity glue system
- Quick size change features
- Left or right hand controls
- Custom voltages
- Modifications for under or oversize cases
- High speeds - over 35 trays per minute
- Choice of hot melt glue systems
- Low hopper sensor
- Motorized outfeed conveyor
- Allen-Bradley or other PLC

MACHINE SPECIFICATIONS

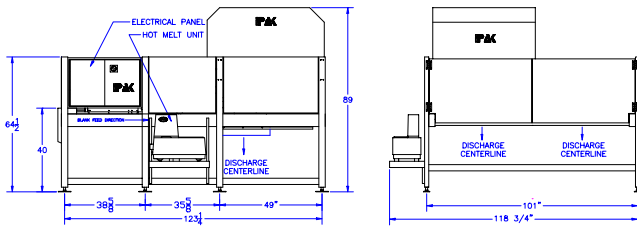

- Machine weight: 4400 lbs. (2032 kg)
- Machine length (typical): 10'6"
- Air: 1.0 cubic feet per cycle at 80 p.s.i.
- Electrical: 230/460 Volts AC, 3 phase, 60 Hz
- Speeds up to 35 trays per minute per side
- PLC operated sequence and timing control
- External digital glue pattern timing controls
- NEMA 12 control panel
- Nordson hot melt adhesive system
- Lock-out / tag-out compliant

FORMING SEQUENCE

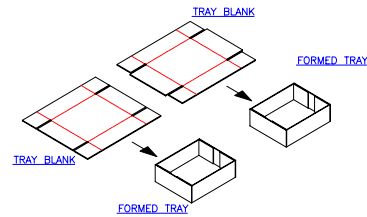

METHOD OF OPERATION

Each TF-200D hopper is loaded with die cut blanks. With each side of the machine operating independently, vacuum cups pull the blanks onto the lug and chain drive. Hot melt adhesive is applied, then the blank is impacted and folded by a forming mandrel, compressed, and ejected upright onto a conveyor ready for filling.

SOME EXAMPLES OF TRAYS FORMED ON THE TF-200D

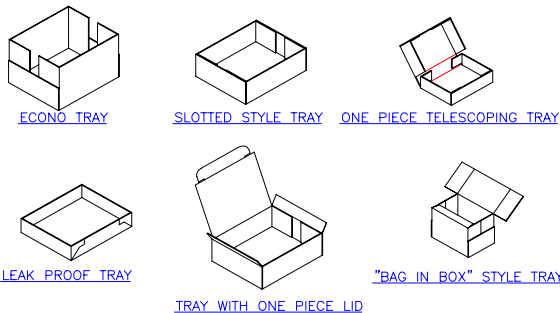

THE IPAK PRODUCT LINE INCLUDES:

- | | |
|-----------------|--------------------------|
| Tray Formers | Flange Sealers |
| Case Sealers | Stackers and De-Stackers |
| Sleeve Wrappers | Custom Applications |

DISTRIBUTED BY:

IPak Machinery Ltd.

160-6165 Highway #17, Delta, BC, Canada V4K 5B8 Phone (604) 940-8073 Fax (604) 940-8074
 Email: sales@ipakmachinery.com www.ipakmachinery.com